

LINEEYE®

USB Protocol Analyzer

2.0 / 1.1

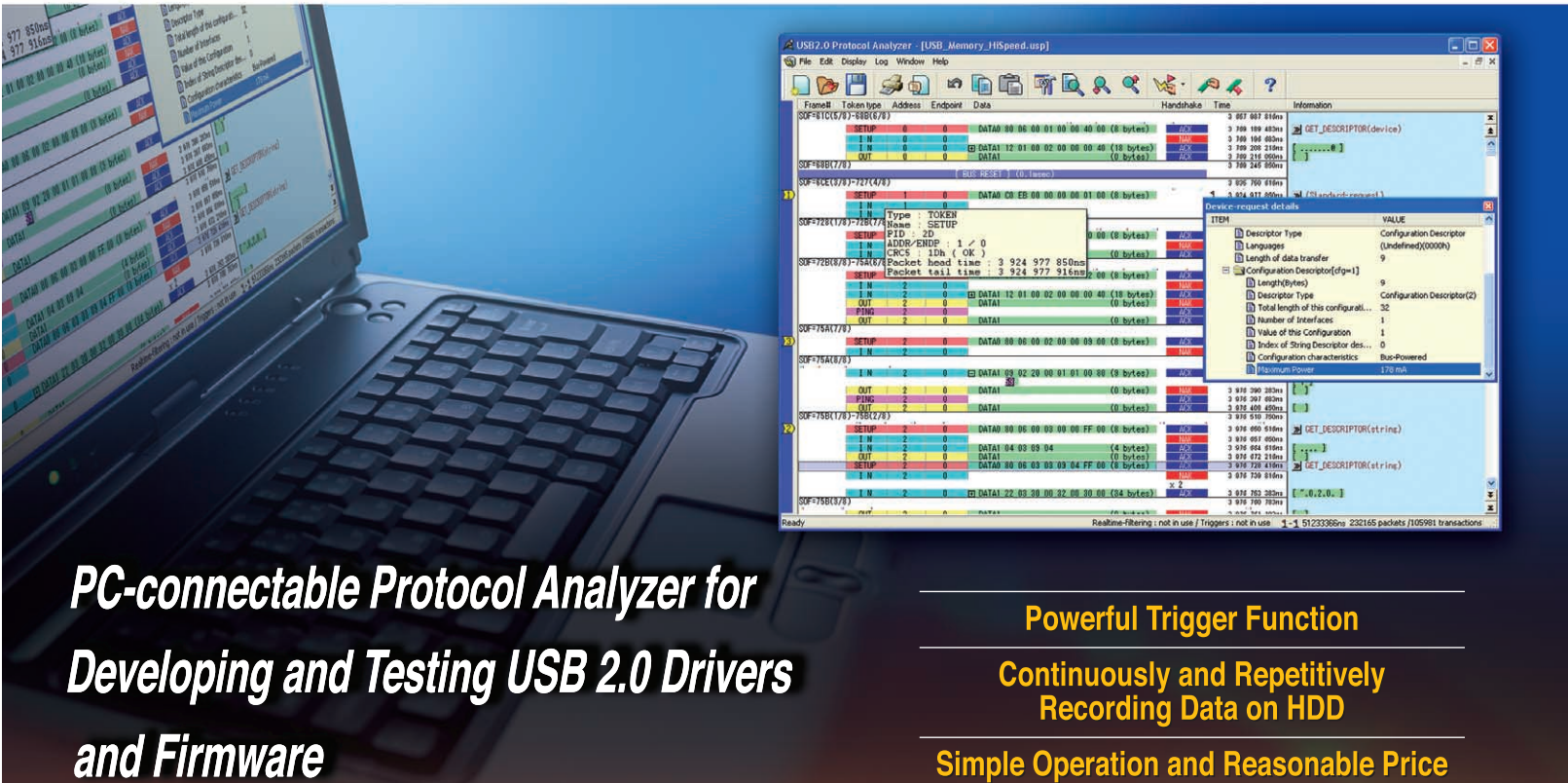

**PC-connectable Protocol Analyzer for
Developing and Testing USB 2.0 Drivers
and Firmware**

Powerful Trigger Function

**Continuously and Repetitively
Recording Data on HDD**

Simple Operation and Reasonable Price

High-speed (480 Mbps) Support
NEW [New Firmware Ver. 3]

Japanese
Version

LE-620HS

English
Version

LE-620HS-E

Full-speed (12Mbps) Support **NEW**

Japanese
Version

LE-610FS

English
Version

LE-610FS-E



- ▶ Max. 480 Mbps support
- ▶ Continuous 20 Gbyte recording
- ▶ External eight channels of trigger data



- ▶ Max. 12 Mbps support
- ▶ Continuous 10 Gbyte recording
- ▶ External one channel of trigger data

USB Protocol Analyzer LE-620HS / LE-610FS

The LE-620HS and LE-610FS are USB protocol analyzers dedicatedly designed for monitoring and used in connection with the PC through a USB port. Each model continuously records the details of USB 2.0/1.1 communication on the hard disk of the PC in real time while displaying the details on the monitor screen of the PC in an easy-to-understand fashion.

Auto Tracking of High-speed USB Transmission

Without affecting the communication line carrying data between the analyzer and target devices, the LE-620HS and LE-610FS internally record large amounts of data and simultaneously transfer it to a connected PC via USB. The analyzers automatically detect the speed of the target devices (480¹/12/1.5 Mbps), so a speed setting is unnecessary. And if the device is connected through a hub of differing speed, measurement can be started by simply pressing the space bar of the PC.

*1: The LE-610FS does not support high-speed (480 Mbps) transfer.

[Connection Method]

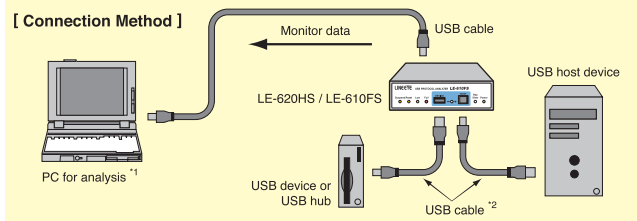

*1 It is recommended to install the provided analysis software to a PC model incorporating a high-speed USB 2.0 port. If a full-speed USB port is used, however, data recording only to the built-in memory of the analyzer will be guaranteed. If the USB host used for measurement is a PC model supporting the operating conditions of the analyzer, the PC model can be used for analysis purposes as well.

*2 It is recommended to keep the length of each cable not exceeding the maximum limit specified for USB communication.

Continuous Repetitive Recording of Measurement Data on HDD

Measurement data captured by the analyzer is continuously transferred to the PC for analysis via USB port and recorded as a log file with a maximum of 2 GB on the hard disk of the PC. Furthermore, it is possible to form a ring buffer to record multiple log files continuously by using repetitive recording mode. The measurement log data can be displayed and scrolled during measurement, which is effective for an extended analysis of rare communications failures under indefinite conditions.

	Log file size	Number of log files while in repeat mode	Maximum recording capacity
LE-620HS	1 to 2,048 Mbytes	2 to 10	20 Gbytes
LE-610FS	1 to 2,048 Mbytes	2 to 5	10 Gbytes

Clearly Detailed Monitor Display

USB packets are clearly displayed by transaction. The LE-620HS can identify PING and the split transaction at high speed. Standard requests and descriptors are translated and displayed in detail, therefore the difficult-to-understand USB protocols can be intuitively understood. And, the LE-620HS supports a wide range of device-specific descriptors.

Note : The above screen is a display example of the LE-620HS. The LE-610FS is basically the same as the LE-620HS in display except the display of high-speed transfer, which is enabled by the LE-620HS only.

- ① Multiple packets are grouped and displayed on a single line by transaction.
- ② Only the first 8 bytes of data packets are displayed. Clicking the [+] mark displays all data.
- ③ The selected transaction is highlighted with the operation of the mouse.
- ④ The USB state (i.e., the bus reset, suspend, or disconnection state) is recorded and displayed along with communication data.
- ⑤ The target transaction can be marked with 1 to 99, and can jump to the marked positions.
- ⑥ Displays the SOF (Start of Frame) frame number. At high speed, microframes are displayed as (1/8) to (8/8). At low speed, nothing is displayed in this column because no SOF packets are generated.
- ⑦ Records and displays the time stamp at a resolution of 16.7 ns.

- ⑧ Visibility of continuous NAK packets is improved by displaying only those cycles.
- ⑨ Displays the details of each transaction and frame.

Token packet	Packet type, packet name, PID, address/endpoint, CRC5, packet start, and completion time
Data packet	Packet type, packet name, PID, payload, CRC16, packet start, and completion time
Frame	Frame period, packet start, and completion time

- ⑩ Clicking the [>>] mark displays a detailed translation window of the device request. Descriptors are displayed as a tree view to show their hierarchical structure.
- ⑪ When a device request item is selected for transaction, the corresponding data in the data packet is highlighted.

USB Protocol Analyzer LE-620HS / LE-610FS

Specifications

Model	LE-620HS	LE-610FS
Standard	USB 2.0 / 1.1	USB 2.0 / 1.1 ^{*1}
Speed	HIGH (480Mbps) / FULL (12Mbps) / LOW (1.5Mbps) Automatically judged and selected	FULL (12Mbps) / LOW (1.5Mbps) Automatically judged and selected
Storage capacity	Analyzer	Capture memory: 256 MB
	PC	Hard disk: Max. 20 GB (Can be specified every 1 MB)
Recording method	By bytes including sync patterns ^{*2} Data is recorded on the hard disk of the PC through the built-in capture memory of the analyzer. Continuous repetitive recording in a number of files is possible.	
Packets	SOF, IN, OUT, SETUP, DATA0, DATA1, ACK, NAK, STALL, PRE, DATA2, PING, MDATA, SPLIT, ERR, NYET, and Unknown (undefined).	
Time stamp	High-precision time measurement ON: Resolution of 16.7 ns for 5 hours max. High-precision time measurement OFF: Resolution of 125 μ s/1 ms in USB (micro) frame time units	
Filter function	Log	IN-NAK/OUT-NAK/SETUP-NAK/PING with or without multiple particular address/end points specified.
	Display	SOF, NAK, SETUP, and PING with or without particular address/end points displayed.
Trigger	Condition	Particular address/end points, packet types (TOKEN and HAND SHAKE packets in combination), errors (bit stuffing, CRC, and PID errors), data packets (8 bytes max, hexadecimal/decimal/binary input or character train input, with or without bit mask specification), and external trigger (edge or level specification possible).
	Action	Possible to specify 16 actions enabled with log start, log stop, and external trigger output (with or without levels or pulses specified) in combination with conditions.
	External	8-point external trigger input and 8-point external trigger output Connector: 20-pin male (OMRON's XG4C-2034 or equivalent one) Electrical specifications: LVTTTL
Search function	SOF, IN-Token, OUT-Token, SETUP-Token, DATA-Packet, PING, ACK, NAK, STALL, NYET, Unknown, CRC-Error states, multiple specific address/end points in combination, and idle status more than the specified value can be searched.	
Color display customization	SOF, IN, OUT, SETUP, DATA0, DATA1, ACK, NAK, STALL, PRE, DATA2, PING, MDATA, ERR, NYET, Unknown (undefined), SetupDetail, and display can be color coded separately.	
Detailed display	Standard requests, peculiar device requests to HUB/HID/Audio/Communication class, standard descriptors, and HUB/HID/Audio/Communication/Mass storage (SCSI Command Parents Set, ATAPI SFF-8070i) descriptors in each class can be displayed in detail. ^{*3}	
Statistic analysis function	The number of transactions and the number of transfer bytes in measured data are totaled and displayed together with the average transfer rate. The results of totaling can be used for table calculation software.	
Mark/Jump functions	Up to 99 marks can be set in specific recorded data per transaction, and jumping to any marked position or to data coinciding in trigger condition is enabled.	
Save	Saving raw data or data in text or CSV format. Data can be copied and pasted through the clipboard, and saved data can be added with comments.	
Print function	Specified ranges of recorded data can be printed (in monochrome or color as specified).	
Connectors for measurement	USB standard A/B receptacles : 1 each	
PC connector	USB B receptacle : 1 Connected to the USB port of the PC on which the included analysis software has been installed.	
LED indicator	PWR (Power supply): 1, RDY (Ready): 1, (Measured target data): 1, Hi-Full-Low (USB speed): 1 each; Suspend (Suspended state): 1, Reset (Reset state): 1, and RUN (Measuring): 1	Power (Power supply): 1, Rdy/Over (Ready/Overflow): 1, (Measured target data): 1, Full-Low (USB speed): 1 each, Suspend (Suspended state): 1, Reset (Reset state): 1
Switch	POWER (Power supply): 1	—
Power supply	100 to 240 VAC (50/60 Hz) at 10 W max.	
Ambient temperature	In operation: 5 to 40°C, In storage: -10 to 50°C	
Ambient humidity	10% to 90% (No condensation)	
Dimensions and weight	145 (W) x 190 (D) x 45 (H) mm, approx. 950 g	130 (W) x 145 (D) x 38 (H) mm, approx. 300 g
Accessories	Analyzer, analysis software CD, USB cable (x 2), AC cable, carrying bag, instruction manual, and warranty	Analyzer, analysis software CD, USB cable (x 2), instruction manual, and warranty

Note *1: The analyzer does not support the measurement and display satisfying USB 2.0 high-speed transfer specifications.

*2: Waveforms of USB bus signals are not recorded but the USB device status (Bus, Reset, Suspend, and Disconnect) are recorded under the following conditions.

Condition	Recording
Bus Reset	The SEO status of D+/D- signals is detected within a range between 2.5 μ s and 140ms.
Suspend	A non-communication period not in the SEO status is received for 3 ms or over.
Disconnect	The SEO status of D+/D- signals is detected for 140 ms or over.

Note: The USB device status may not coincide with the actual bus state of the applicable device at the time of USB cable connection or disconnection because the D+/D- signals will be stable.

*3: More classes will be supported by future versions of analysis software.

*4: A USB 2.0 port supporting high-speed transfer is recommended. If the transfer speed of the USB port is slow, continuous recording to the hard disk of the PC may not be possible. In that case, only data recorded in the built-in capture memory will be guaranteed.

System Requirements

O/S	Windows	XP / 2000
P C		PC/AT-compatible machine with USB ports
	CPU	Pentium 500 MHz or faster (Pentium processor at 2 GHz or faster is recommended.)
	Memory	Min. 256 Mbytes
	USB port	USB 2.0 port supporting high-speed transfer is recommended. Use the Microsoft EHCI driver as the host controller driver for the USB 2.0 port. When using the USB 2.0 port for an expansion board, such as a PCI board, make sure that the board is operated by the Microsoft EHCI driver.
	Hard disk	Required free bytes: 7.5 MB for installing the analysis software + area for recording communications log.
Display		1024 x 768 or better resolution recommended.

Nomenclature

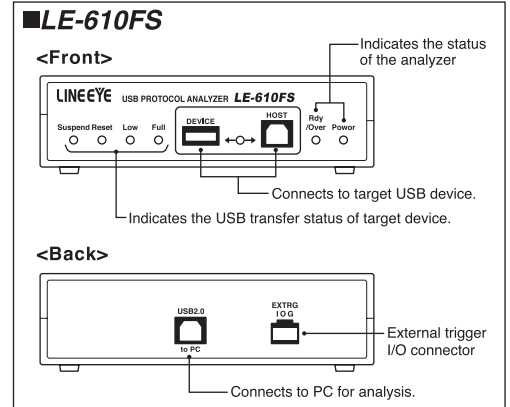
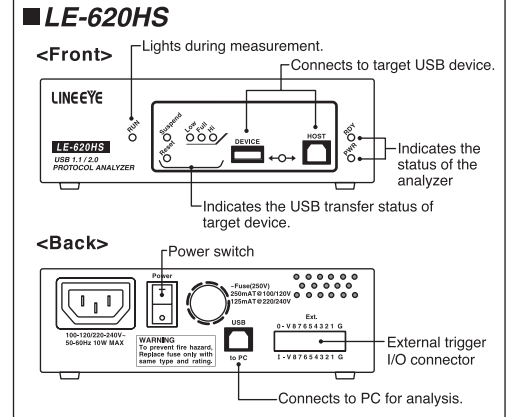

Option

Three-wire Probe Cable LE-3LP



A cable with IC clip terminals suitable to the external trigger I/O connector of the LE-610FS.

Connector with Harness LE-18XG



A connector with loose wires suitable to the external trigger I/O connector of the LE-620HS.



SAFETY WARNING

Read the instruction manual provided with the product carefully before use and be sure to operate the product according to the information given in the instruction manual. Using the product in ways not guaranteed in the manual, connecting the product to systems not within the specified ranges, or the modification of the product can cause trouble and damage. LINEEYE CO., LTD. will assume no responsibility whatsoever for trouble or damage arising because of unauthorized ways of use.

All brand names and product names mentioned in this catalog are trademarks or registered trademarks of respective companies. Specifications and designs of products listed in this catalog are as of January 2006, and are subject to change without notice for improvement. Colors of actual products may differ slightly from those listed due to printing condition. This catalog may not be reprinted or duplicated, in part or in whole.

©2006 by LINE EYE CO., LTD.



Head Office / Sales Office
Marufuku Bldg. 5F 39-1 Karahashi Nishihiragaki-cho Minami-ku Kyoto 601-8468 Japan
Phone: 81-75-693-0161 Fax: 81-75-693-0163

Technical Center
8-49 Koen-cho, Nagahama, Shiga 526-0065 Japan
Phone: 81-749-63-7762 Fax: 81-749-63-4489

URL <http://www.lineeye.com> E-mail : info@lineeye.com

LINEEYE CO., LTD. is a venture company founded by electronic equipment development members of the former Sekisui Chemical Co., LTD. with investment from the Sekisui Venture Fund.



Printed in Japan

L-06201E/LE©